

No. 649,504.

Patented May 15, 1900.

J. R. BACK.  
TURNING LATHE.

(Application filed Feb. 28, 1899.)

(No Model.)

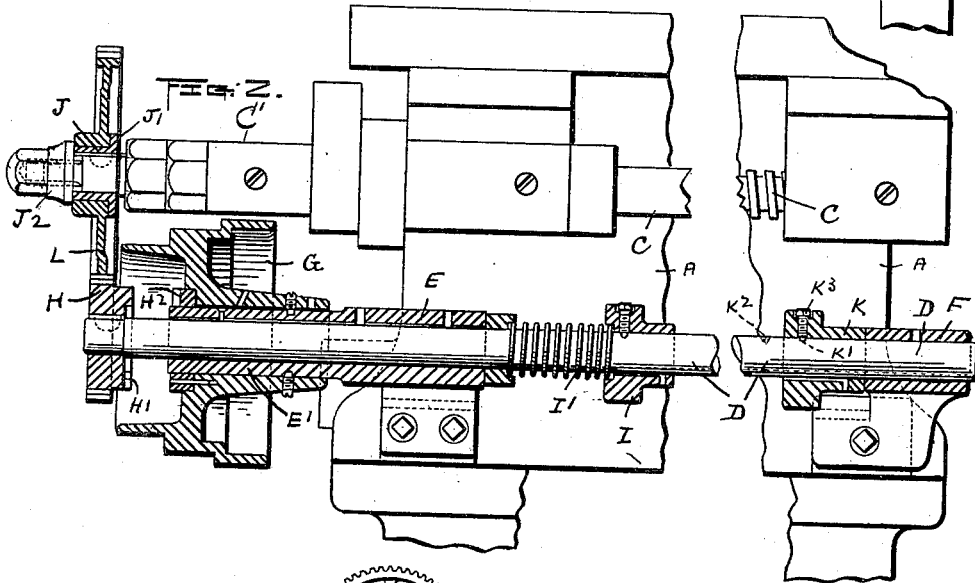
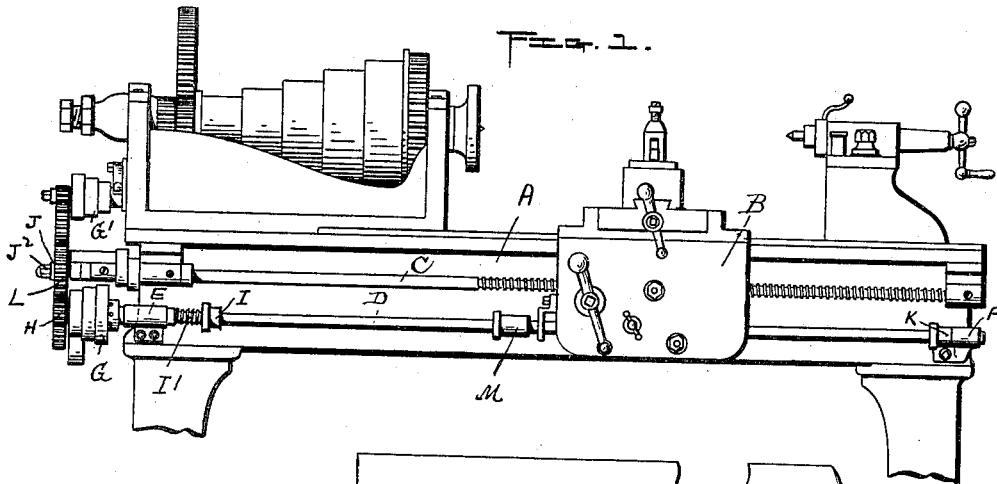
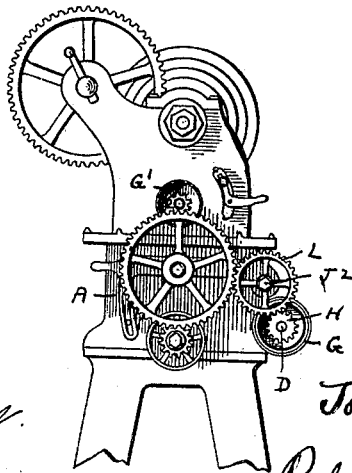

Fig. 3.



Witnesses,  
*C. Forest Nesson.*  
*Elizabeth Gray*

INVENTOR  
*John R. Back*  
 BY *Rufus B. Fowler* ATT.

# UNITED STATES PATENT OFFICE.

JOHN R. BACK, OF WORCESTER, MASSACHUSETTS, ASSIGNOR TO THE F. E. REED COMPANY, OF SAME PLACE.

## TURNING-LATHE.

SPECIFICATION forming part of Letters Patent No. 649,504, dated May 15, 1900.

Application filed February 28, 1899. Serial No. 707,134. (No model.)

*To all whom it may concern:*

Be it known that I, JOHN R. BACK, a citizen of the United States, residing at Worcester, in the county of Worcester and Commonwealth of Massachusetts, have invented a certain new and useful Improvement in Turning-Lathes, of which the following is a specification, accompanied by drawings forming a part of the same, and in which—

10 Figure 1 represents a front elevation of a turning-lathe embodying my invention. Fig. 2 is a front view of a portion of the lathe with the parts concerned in my present invention shown in sectional view, and Fig. 3 is an end  
15 view of the lathe.

Similar reference-letters refer to similar parts in the different views.

My present invention relates to that class of lathes employed for turning metal; and the  
20 objects of my invention are to provide means for driving the feed-rod at will either by a belt or a geared connection with the live-spindle and also to provide means for stopping the feeding motion of the cutting-tool at any  
25 desired point along the bed of the lathe; and it consists in the construction and arrangement of parts, as hereinafter described, and set forth in the annexed claims.

Referring to the drawings, A denotes the  
30 bed of the lathe, and B the carriage, which supports the cutting-tool and is capable of a feeding motion along ways upon the bed of the lathe in the usual manner.

Journalled in bearings upon the front of  
35 the lathe-bed A is a rotating screw-threaded shaft C, known as the "lead-screw," and also a rotating shaft D, known as the "feed-rod." Both the lead-screw C and feed-rod D are operatively connected at will with the carriage  
40 B in order to impart a feeding motion to the cutting-tool by means of mechanism which will be well understood by those conversant with this class of machines, and is therefore not herein described or shown in the draw-  
45 ings.

My present invention relates to the mechanism by which the feed-rod D is driven and automatically disconnected at any desired  
50 point in the movement of the carriage along the ways of the lathe.

The feed-rod D is journalled in bearings E

and F, attached to the lathe-bed, and is capable of longitudinal movement. The bearing E is provided on one side with an extension E', on which a cone-pulley G rotates loosely, 55 having a belt connection with a driving cone-pulley G', operatively connected with the live-spindle of the lathe in the usual manner. Attached to the feed-rod is a gear H, having upon one side clutch-teeth H', arranged to en- 60 gage similar clutch-teeth H<sup>2</sup> on the side of the rotating cone-pulley G. A collar I is attached to the feed-rod D, and between the collar I and the bearing E is a spiral spring I', with its 65 tension applied to slide the feed-rod in its bearings toward the right. The lead-screw C projects beyond its journal-bearing C' and carries a collar J, having a spline connection with the lead-screw and provided on one end with a flange J'. 70

A gear L is held upon the collar J by a nut J<sup>2</sup> and is capable of rotating thereon between the nut and flange J'. The gear L is operatively connected with the live-spindle in the 75 usual manner by what is known as "change-gear" and is adapted to engage the gear H on the feed-rod D when the feed-rod has been moved toward the left far enough to bring the gear H into the plane of the gear L and 80 cause their teeth to engage. The sliding movement of the feed-rod D as it is actuated by the spiral spring I' is limited by a collar K, which is attached to the feed-rod and arranged to bear against the journal-bearing 85 F. Holes K' and K<sup>2</sup> are countersunk in the feed-rod D to receive the set-screw K<sup>3</sup> in the collar K. When the set-screw enters the hole K', the feed-rod is held against the tension of the spring I', with the gear H in engage- 90 ment with the gear L, and when the set-screw K<sup>3</sup> enters the hole K<sup>2</sup> the spring I' is allowed to expand and carry the clutch-teeth H' into engagement with the clutch-teeth H<sup>2</sup>, causing the feed-rod to be driven by the pulley 95 G. Changing the position of the collar J will cause the feed-rod to be driven by either the pulley G or the gear L.

Adjustably attached to the feed-rod D is a collar M in the path of the carriage B as it is traversed along the ways of the lathe. The 100 collar M is placed on the feed-rod D, so that the contact of the carriage B will move

the feed-rod toward the left against the tension of the spiral spring I' when the cutting-tool has traversed across the work held in the lathe. By adjusting the collars, as above described, the feed-rod may either driven by direct connection with the cone-pulley G or by the engagement of the gears H and L, as may be desired, and in either case the stopping mechanism is made to operate to throw the feed-rod D out of engagement with the driving power at any desired point in the traversing motion of the carriage. When the feed-rod is driven by a gear connection from the live-spindle, the gear L is an intermediate gear turning loosely upon the flanged collar K; but in case the lead-screw is to be rotated the gear L and collar K are removed and a gear placed upon the lead-screw having a spline connection therewith and adapted to be driven in the usual manner from the live-spindle. When the feed-rod is driven from the gear L, a positive feeding motion is given to the carriage B and a greater variation of the feeding motion is secured by means of the change-gears of different diameters provided with a lathe for varying the speed of the lead-screw in the usual and well-known manner.

What I claim as my invention, and desire to secure by Letters Patent, is—

1. In a metal-turning lathe, the combination with a feed-rod capable of a longitudinal movement in its bearings, of a rotating pulley journaled concentrically with said feed-rod, a clutching mechanism between said pulley and said feed-rod arranged to be operated by the sliding motion of the feed-rod, a rotating driving-gear, a gear attached to said feed-rod and arranged to be carried into and out of engagement by the sliding motion of said feed-rod, whereby said feed-rod is driven at will by said driving-gear or by said pulley, substantially as described.

2. In a metal-turning lathe, the combination of a carriage, a feed-rod by which said carriage is traversed along the bed of the lathe, said feed-rod being capable of a longitudinal movement in its bearings, a driving-pulley, a clutching mechanism between said driving-pulley and the feed-rod, a driving-gear, a gear attached to said feed-rod and arranged to be brought into engagement with said driving-

gear, a spiral spring by which said feed-rod is moved lengthwise in one direction to bring said feed-rod into engagement with the driving power, means for engaging said feed-rod with the carriage to move it in the opposite direction and disengage it from the driving power, and an adjustable collar carried by said feed-rod, by which its position is determined either in engagement with said driving-pulley or with said driving-gear, substantially as described.

3. In a metal-turning lathe the combination with a feed-rod capable of a longitudinal movement in its bearings, of a rotating pulley journaled concentrically with said feed-rod, a clutching mechanism between said rod and said pulley and arranged to be operated by the sliding motion of said rod, a driving-gear, a gear attached to said feed-rod and arranged to be carried into and out of engagement by the sliding movement of said rod and a spring applied to said rod to move it in one direction, substantially as described.

4. In a metal-turning lathe, the combination with a feed-rod capable of a longitudinal movement in its bearings, a spring by which said rod is moved in one direction, a collar adjustably attached to said rod and in the path of the tool-carriage of the lathe, an independently-rotating pulley having clutch-teeth, clutch-teeth carried by said feed-rod arranged to engage the teeth on said pulley, a driving-gear and a gear on the feed-rod arranged to engage said driving-gear, substantially as described.

5. The combination with a carriage and a feed-rod capable of an endwise movement, of a pulley G, a clutching mechanism between said feed-rod and said pulley, a driving-gear L and gear H attached to said rod, a spiral spring I' by which said feed-rod is moved in one direction an adjustable collar M in the path of the carriage and an adjustable collar K, by which the action of said spiral spring is limited to hold the feed-rod in operative connection with either said pulley G or said gear L, substantially as described.

Dated this 23d day of February, 1899.

JOHN R. BACK.

Witnesses:

RUFUS B. FOWLER,  
ELIZABETH GRAY.